



LIQUINOVA

Group

TRANSPAK ✖ VIPOLL ◻ LAMBRECHTS ||| NEW CROWN @ ezs
easy solutions



TO SERVE THE **GLOBAL** BEVERAGE AND LIQUID FOOD INDUSTRY

OFFERING **CUSTOMIZED** SOLUTIONS AND **360° SERVICES**

AS A MACHINE **MANUFACTURER** AND LINE **INTEGRATOR**

For **CLEANING, PREPARATION, FILLING** and **PACKAGING**

THROUGHOUT THE **ENTIRE LIFE CYCLE** OF THE EQUIPMENT

Liquinova Group Global footprint



Overview Vipoll

FILLING EQUIPMENT (rinsers / fillers / capper block) FOR BEVERAGES	<p>Combined systems for:</p> <ul style="list-style-type: none"> ▪ Glass + PET ▪ Glass + can ▪ Glass + can + PET ▪ Can + PET <p style="text-align: right; background-color: #008080; color: white; padding: 2px;">COUNTER-PRESSURE FILLERS ONLY</p> <p>Dedicated fillers for:</p> <ul style="list-style-type: none"> ▪ Glass bottles (also Aluminum bottles possible) ▪ Cans ▪ PET bottles
PROCESS EQUIPMENT	<ul style="list-style-type: none"> ▪ Product stabilization ▪ Product preparation ▪ CIP cleaning ▪ Tailored solutions
OTHER	<ul style="list-style-type: none"> ▪ Bottle / can conveyors ▪ Lid servers ▪ Gravity can rinser ▪ Can turners

Vipoll competitive in	Explanation
ALL-IN-ONE or SMALL-IN-ONE fillers → Fillers for cans and bottles in one machine	VIPOLL has the leading position in this solution with numerous references
Multiple containers on a single machine	VIPOLL has a lot of experience of handling many different containers
Multiple closures (caps and/or lids)	Combination closing turrets available that reduce space and time in changeover
Need for more hygiene, e.g. Closure disinfection → LID disinfection	VIPOLL can provide wet LID disinfection
Lead time	SMALL-IN-ONE is available within 6 months of delivery (it was designed to not be impacted by supply chain shortages in electronics)

Overview Transpak

PACKAGING EQUIPMENT	<p>Standard machines:</p> <ul style="list-style-type: none"> ▪ Universal palletizers ▪ Sweep of depalletizers ▪ Craters and decraters ▪ Crate & KEG palletizers and depalletizers <p>Robotic Solutions:</p> <ul style="list-style-type: none"> ▪ Depalletizing an palletizing of crates ▪ Depalletizing of glass bottles and cans ▪ Depalletizing of palletizing of kegs ▪ With universal head for depalletizing an palletizing
CONVEYORS	Conveyors for glass bottles, cans, PET bottles, packs, trays, crates, kegs, palets and other
OTHER	Bottling line audits Safety audits Line upgrades and relocations

Transpak competitive in	Explanation
RGB lines, partly also OW and CAN lines	Long term experience/ knowledge/references in RGB & can lines. Able to offer numerous machines from own production
Line upgrades with Dry part only	Flexible to adapt to existing line situations, on very competitive level
Complex lines	Either from product specifics, layout execution, flexible to adapt to customers specific requirements
Robotic solutions	State of the art robotic solutions and integration
Middle to high capacity lines	Equipment is developed for middle to high capacity for 24/7 operations on high industrial standards
Line integration	Full line integration, project management, audits and 3 rd party integration

Overview Lambrechts

SEMI AUTOMATIC KEGGING UNITS	CLEANING <ul style="list-style-type: none"> NANO MICRO CLEANING & FILLING <ul style="list-style-type: none"> COMPACT FILLING <ul style="list-style-type: none"> OMNI 	15 to 120 KEGS/H
ALL IN ONE KEGGING MACHINES	CLEANING & FILLING <ul style="list-style-type: none"> SLIMLINE MONOBLOC 	40 to 100 KEGS/H
KEG PROCESSING LINES	CLEANING & FILLING <ul style="list-style-type: none"> ROBOT PROCESSING CELLS LINEAIR PROCESSING CHUNNELS 	100 to 1000 KEGS/H

Lambrechts competitive in	Explanation
Complex lines < 240 KEGS/H (based on customer requirements)	Deep experience including robot palletizing & integration
Robotic solutions	Quick start-up for a wide range of keg treatments (Palletizing, Capper, Spear tightener, etc.)
Well-known and reliable machine	Oldest currently operating machine → 45 years
Short delivery time for standard machines	< 12 weeks for a Compact
Production analysis software	KegBridge
Hotline Service	Fast customer service with extensive experience

Overview New Crown

SERVICES	Engineering services <ul style="list-style-type: none"> Upgrades and Retrofits of (glass) bottling equipment Bottle washer – bottle filler & pasteurizer solutions End of line solutions Automation and electrical upgrades Line optimization Line re-location Onsite services <ul style="list-style-type: none"> Installation & Commissioning Project management Audits and inspections Maintenance services and customer follow-up Troubleshoot and repairs Software and automation services
PRODUCTS	<ul style="list-style-type: none"> Optimizing by restoring to basic conditions Optimizing by replacing subassemblies Optimizing by automating processes Spare parts

NCSP competitive in	Explanation
Customer Intimacy	Delivering customized solutions that address specific client requirements.
Flexibility	Quickly adapting to client needs and changing project scopes with agility and efficiency.
Timely delivery	Majority of projects completed within six months from purchase order.
Technology	Utilizing mordem bottle washing technologies with the capability to integrate the latest innovations on older machines.
Versatility	Able to service and retrofit all RGB bottling equipment across brands (excluding labelers and inspection equipment).
Local Service Team	Network of local partners for fast support.



VIPOLL

Company presentation

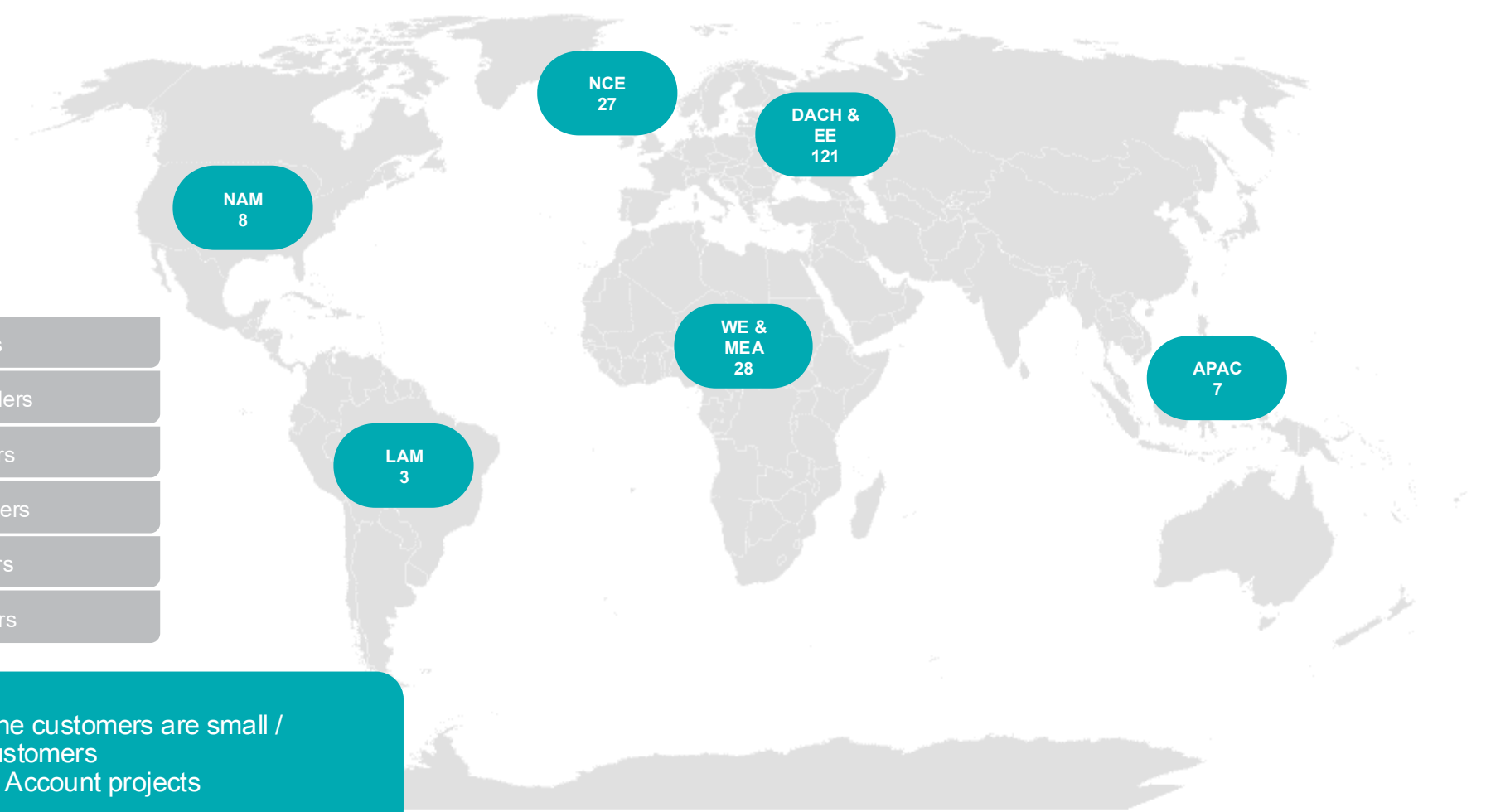

- Fillers, last 15 years
- 5 x Small in One Fillers
- 32 x All in One Fillers
- 80 x All in Glass Fillers
- 29 x All in Can Fillers
- 50 x All in PET Fillers

App. 80% of the customers are small / middle size customers
Low % of Key Account projects

Product portfolio



PROCESS – product stabilization



WINE FILTRATION

- Single line or multiline
- Sterile filtration
- Suprapak filtration
- Option: Integrated stand-alone CIP station for filtration



FLASH PASTEURIZING

- High flexibility fitting for beer, hot fill & cold fill soft drinks and UHT
- Accurate PE control
- Different products, different Heat exchanger types
- Plate 16bar
- Wide stream (pulp)
- Tubular (single/multi tube)
- Option: hot degassing with aroma recovery



SPECIAL APPLICATION

- Yeast dosing
- Color dosing
- Hot & cold product deaeration
- Changeable holding zone for different PUs

Product portfolio



PROCESS – preparation & cleaning



MIXING & CARBONIZATION

- Multiple beverage applications
- CSD mixing and carbonation
- High dosing accuracy for syrup and CO2
- real time dosing corrections for CO2 and Brix following sensor readouts
- Option: in-line water degassing system



WATER DEAERATION

- High flexibility adapted to requirements (process or product), e.g.
- column degassing for high gravity brewing, residual oxygen <0.025 ppm
- vacuum degassing for soft drink production for the finished product <1.0ppm
- Stripping gas either N2 or CO2



CIP

- Multiple beverage applications
- Single or Multiline stations
- fitting number of CIP tanks
- Chemical + Disinfection
- Automatic (CD, T*, flow, time) or manual execution
- Several independent CIP circuits (internal and external)
- real time CIP-ing quality check-up

References & Clients



Ab-InBev • Appenzeller Bier • Beer Select • Birra Peja
• Brasserie Du Bocq • Brasserie du Pays Flamand • Brasserie St. Feuilien
• Brouwerij Anders • Brouwerij Lindemans • Brouwerij Timmermans • Brasserie Bap Bap •
Brasserie 3Monts • Saint Sylvestre • Brasserie Champigneulles • Carlsberg • Danone
Evian • De Proef Brouwerij • Grands Chais de France • Heineken •
Hochschule Geisenheim • Koppabergs Bryggeri • Mautner Markhof • Molson Coors •
Namibia Breweries • Nectar • Pcam Beverage • **Pepsico** • Pernod Ricard •
Privatbrauerei Eichbaum • Pivara Tuzla • Pittsburgh Brewing Company • Radgonske Gorice •
Weingut Schloss Fels • Voelkel • Zwack Unicum

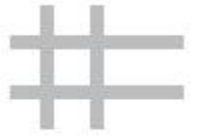

TRANSPAK

Company presentation

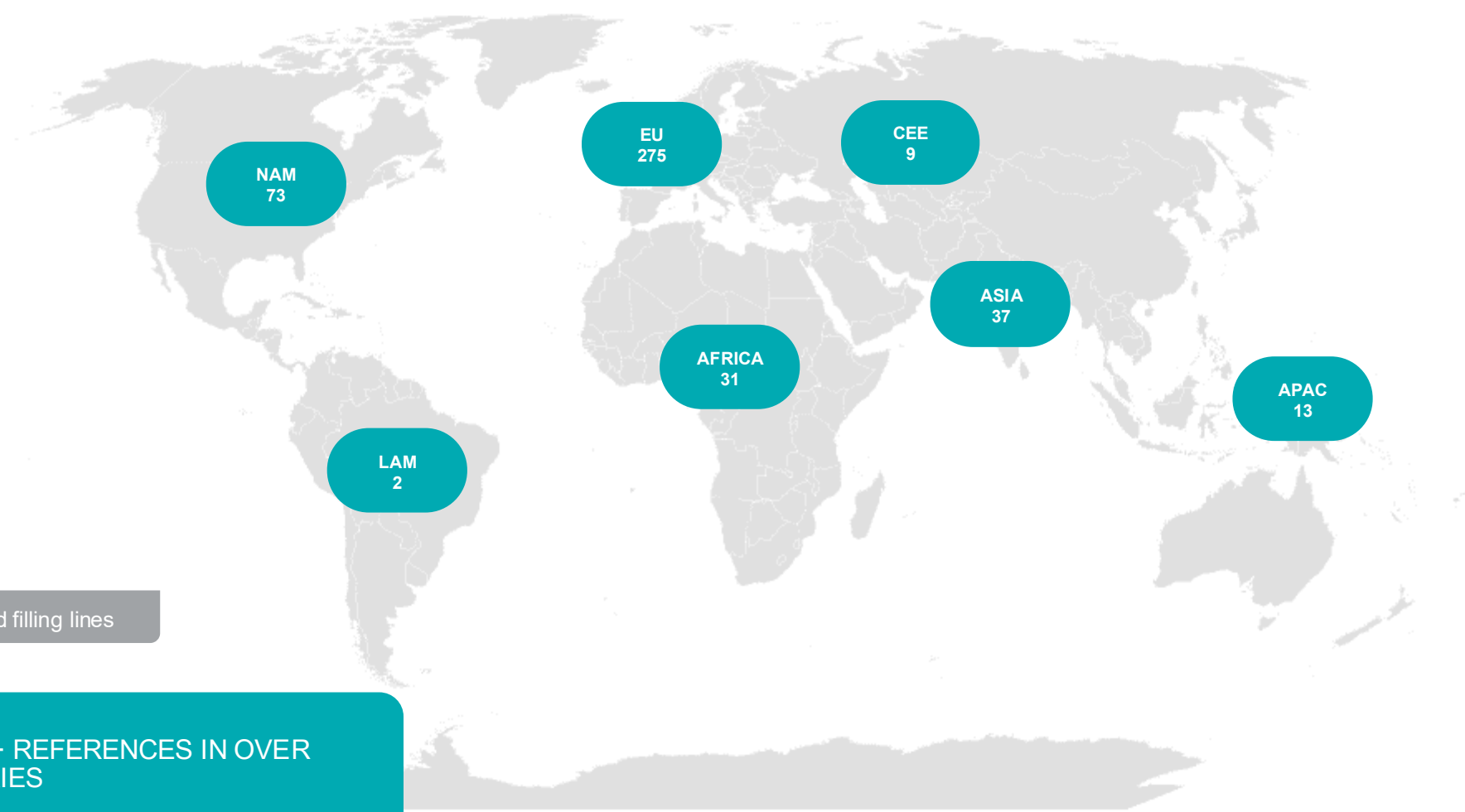
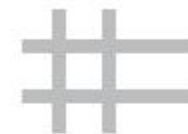

440 – Keg wash and filling lines

In total 1,200+ REFERENCES IN OVER 100 COUNTRIES

TRANSPAK

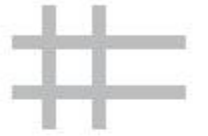

PACKAGING EQUIPMENT	<p>Standard machines:</p> <ul style="list-style-type: none">▪ Universal palletizers▪ Sweep of depalletizers▪ Craters and decraters▪ Crate & KEG palletizers and depalletizers <p>Robotic Solutions:</p> <ul style="list-style-type: none">▪ Depalletizing an palletizing of crates▪ Depalletizing of glass bottles and cans▪ Depalletizing of palletizing of kegs▪ With universal head for depalletizing an palletizing
CONVEYORS	Conveyors for glass bottles, cans, PET bottles, packs, trays, crates, kegs, palets and other
OTHER	Bottling line audits Safety audits Line upgrades and relocations



CORE BUSINESS

Combination of pall & depall

- Royal B & Royal U
- Royal BH & Royal UH
- Including conveyors
- Full line integration

Other

- Crater & Decrater
- Including conveyors

Product portfolio

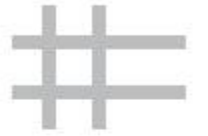

Universal Palletizers and Depalletizers – COMPACT / STANDARD / HIGH CAPACITY

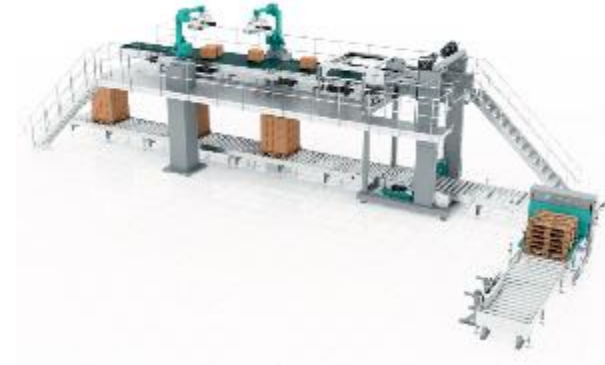
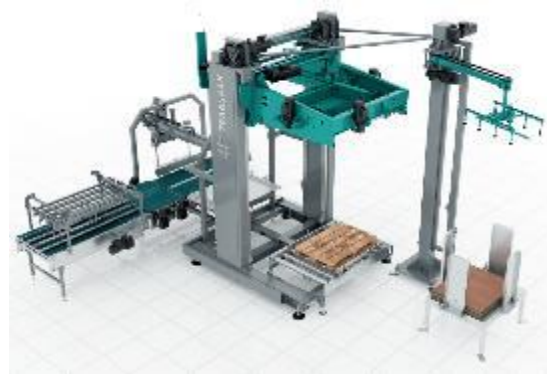

Product portfolio

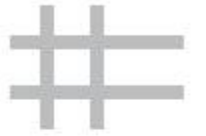

Universal Palletizers and Depalletizers – SINGLE COLUMN EXECUTION



Product portfolio

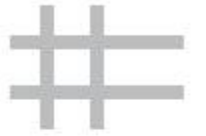

Crate Palletizers and Depalletizers

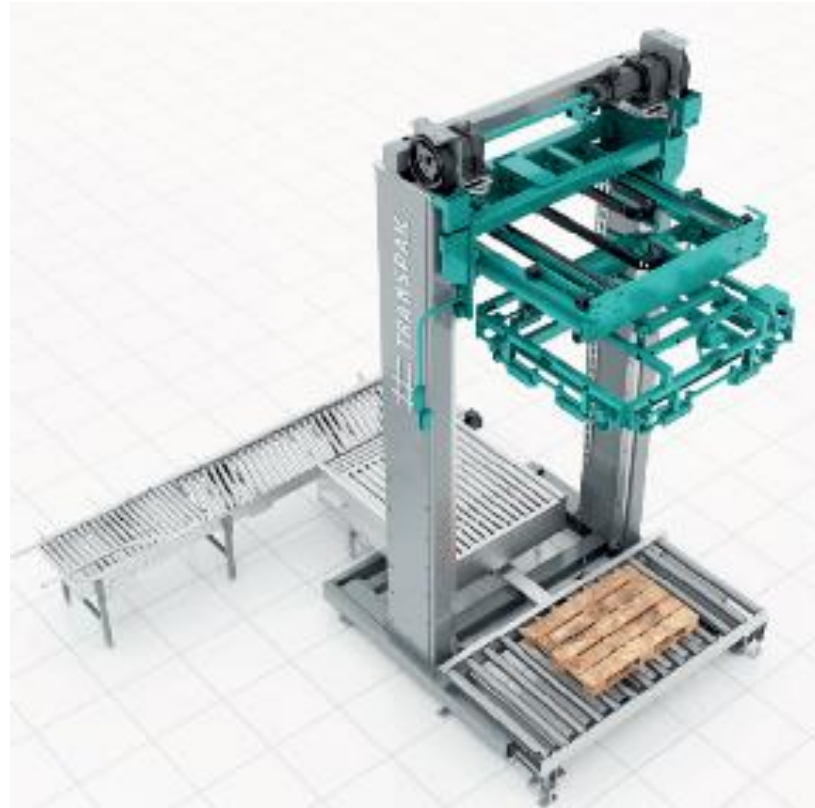

Product portfolio

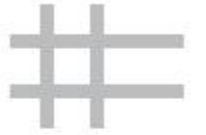

Craters and Decraters – COMPACT AND STANDARD



Product portfolio

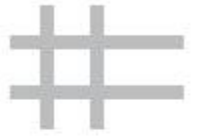

Robotic Solutions



Product portfolio

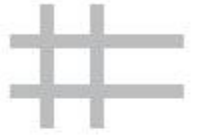

Conveyors

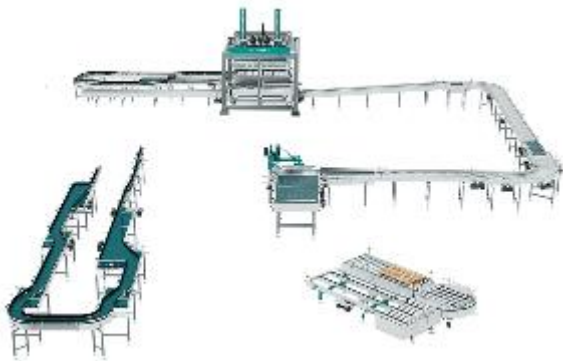

Standard product – high level of experience & knowledge in company. Repeating the projects

High capacities – up to 90k per hour in glass and up to 120k per hour in cans

Very competitive from Price & Technical aspect

– starting to be one of preferred suppliers by some Key accounts, e.g. Asahi

Relatively short time frame of project from start to completion

– quickly moving to next projects in line

Sales generator – approx. 15% mio EUR of sales in projects total in last 4-5 years

Image builder – top level quality

Market position towards Key Accounts –

one of the main products on the start and end of their lines

Minimum to no technical exposure due to no 3rd party

equipment - e.g. 3rd party equipment not reaching efficiency

References & Clients

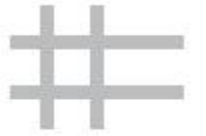

Ab-InBev • Adelholzener Mineralquellen • Alfa Bier • **AmBev** • **Asahi** • Aquamark • Baileys • Bayer • Beer Select • **Berglandmilch** • Birra Peja • **Brasserie Du Bocq** • Brasserie d'Orval • Brasserie du Pays Flamand • **Brasserie St. Feuilien** • Brauunion • **Brouwerij Anders** • Brouwerij Bosteels **Brouwerij Lindemans** • Brouwerij Huyghe • **Develey Senf & Feinkost** • Brasserie Bap Bap • Brasserie 3Monts Saint Sylvestre • Brothers Drinks • Brouwerij Van Honsebrouck • Greenyard • Brouwerij Van Honsebrouck • **Carlsberg** • **Coca Cola** • Danone • De Proef Brouwerij • **Diageo** • Erkrather Quellen • Felix • Friesland Campina • Golden Eagle • Grant's • GSK • Haaner Felsenquellen • **Heineken** • Heinz • Het Anker • Irish Distillers • Katlenburger Kellerei • Lackmann Fleisch • Lindeboom • L'européenne d'embouteillage • Leroy Breweries • **Maspex** • Mautner Markhof • **Molson Coors** • **Namibia Breweries** • Natra Malle • Naturalis-Cetina • Nestle Waters • Oriental Brewery • Old Bushmills Distillery • Pauwels Herent • Pepsico • Pet Food Austria • **Radeberger Gruppe** • Refresco • Ströck-Brot • Sulimar • Texelse Bierbrouwerij • **Unilever** • Volvic Danone • Weetabix



LAMBRECHTS

Company presentation

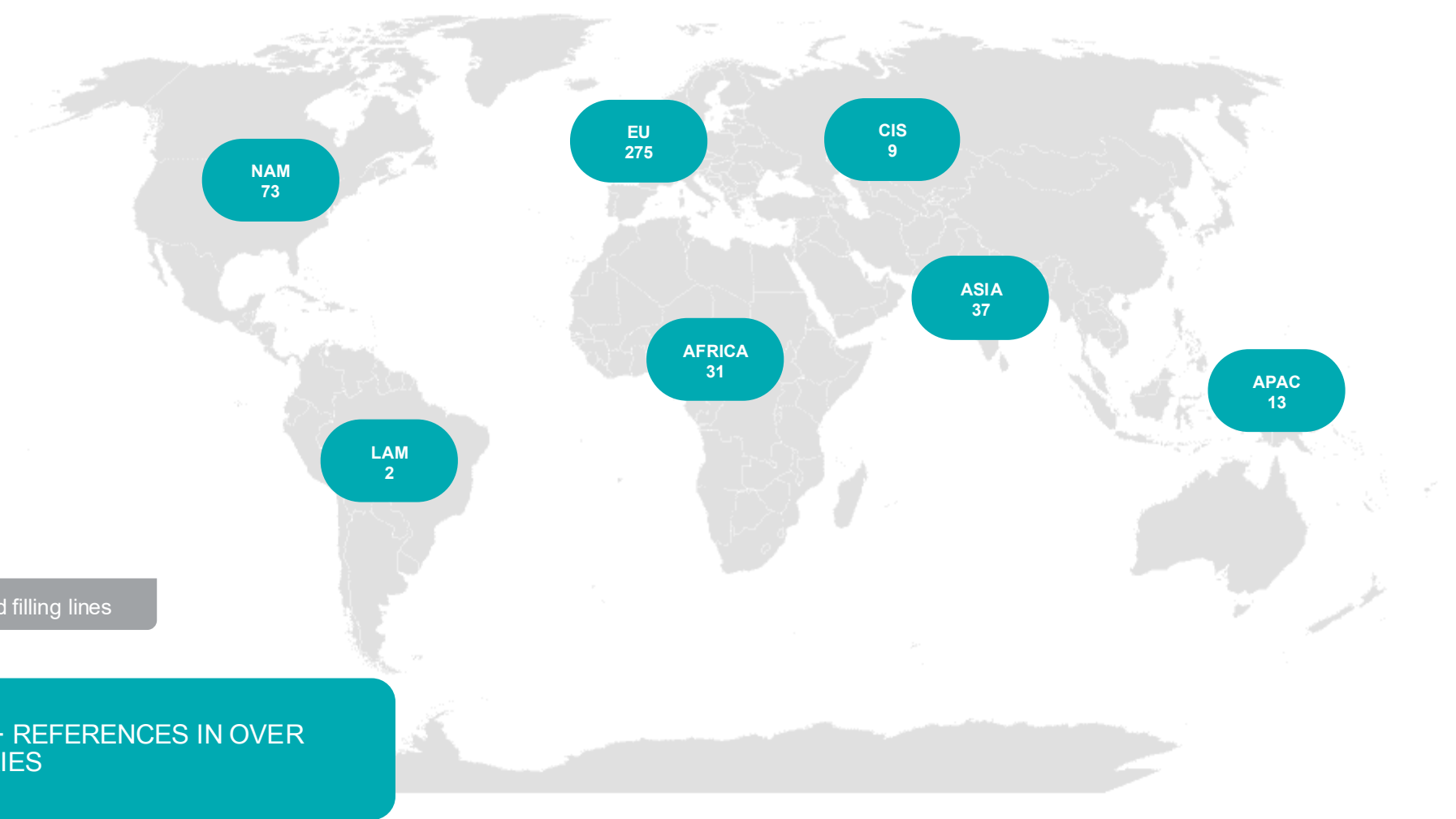

440 – Keg wash and filling lines

In total 1,200+ REFERENCES IN OVER 100 COUNTRIES



LAMBRECHTS



SEMI AUTOMATIC KEGGING UNITS

CLEANING

- NANO
- MICRO

15 to 120 KEGS/H

CLEANING & FILLING

- COMPACT

FILLING

- OMNI

ALL IN ONE KEGGING MACHINES

40 to 100 KEGS/H

CLEANING & FILLING

- SLIMLINE
- MONOBLOC

KEG PROCESSING LINES

CLEANING & FILLING

- ROBOT PROCESSING CELLS
- LINEAR PROCESSING CHUNNELS

100 to 1000 KEGS/H

SEMI AUTOMATIC KEGGING UNITS



NANO (Cleaning)



MICRO (Cleaning)



COMPACT (Cleaning + Filling)



OMNI (Filling)



 Stainless steel keg
 One way keg without bag
 One way keg with bag

Product portfolio



SEMI AUTOMATIC KEGGING UNITS

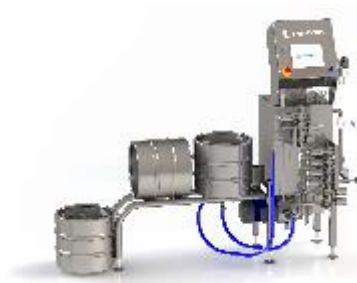

NANO (20 Keg/h)

Cleaning SS-kegs

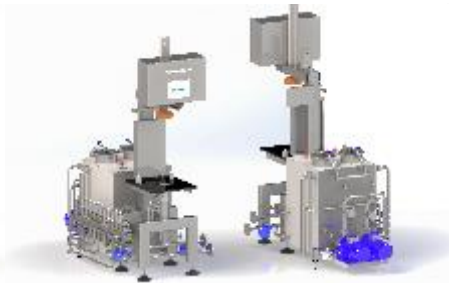

MICRO (25 Keg/h)

Cleaning SS-kegs



COMPACT (35 Keg/h)

Cleaning SS-kegs
Filling OW-kegs



OMNI (60 Keg/h)

Filling SS-kegs
Filling OW-kegs





ALL IN ONE KEGGING MACHINES

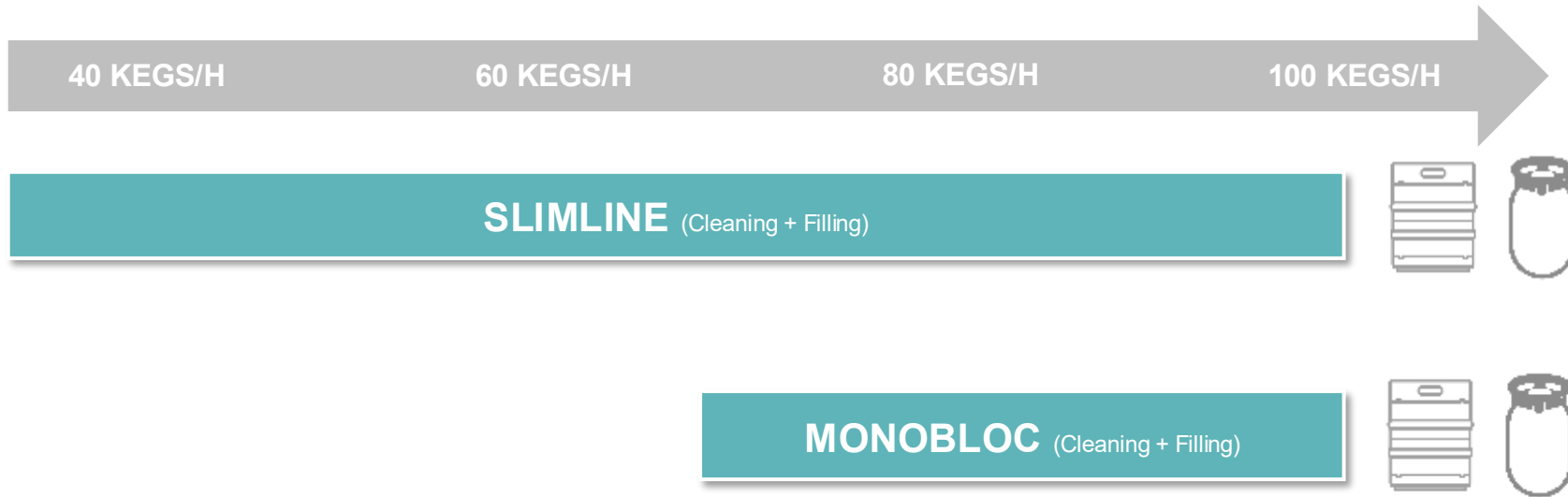

 Stainless steel keg

 One way keg without bag

 One way keg with bag

Product portfolio



ALL IN ONE KEGGING MACHINES



SLIMLINE (50 - 100 Keg/h)

Filling SS-kegs & One way kegs without bag



Optional: External washer



MONOBLOC (50 - 100 Keg/h)

Filling SS-kegs & One way kegs without bag



Optional: External washer

KEG PROCESSING LINES



Robot processing cells (Cleaning + Filling)



Linear processing channels (Cleaning + Filling)



Product portfolio



Robot processing cells up to 450 Keg/h

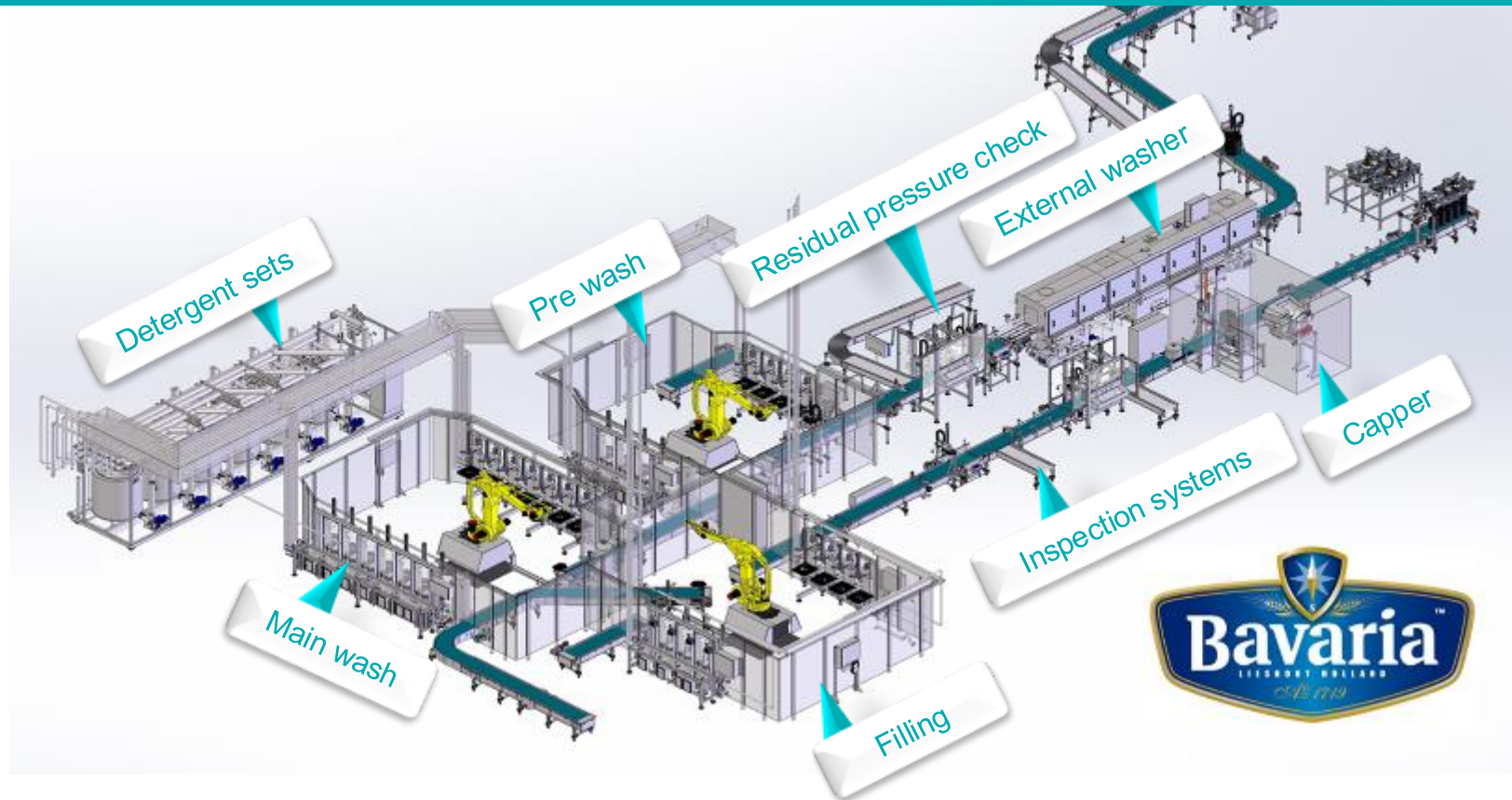

Product portfolio



Linear processing chunnels up to 1,000 Keg/h

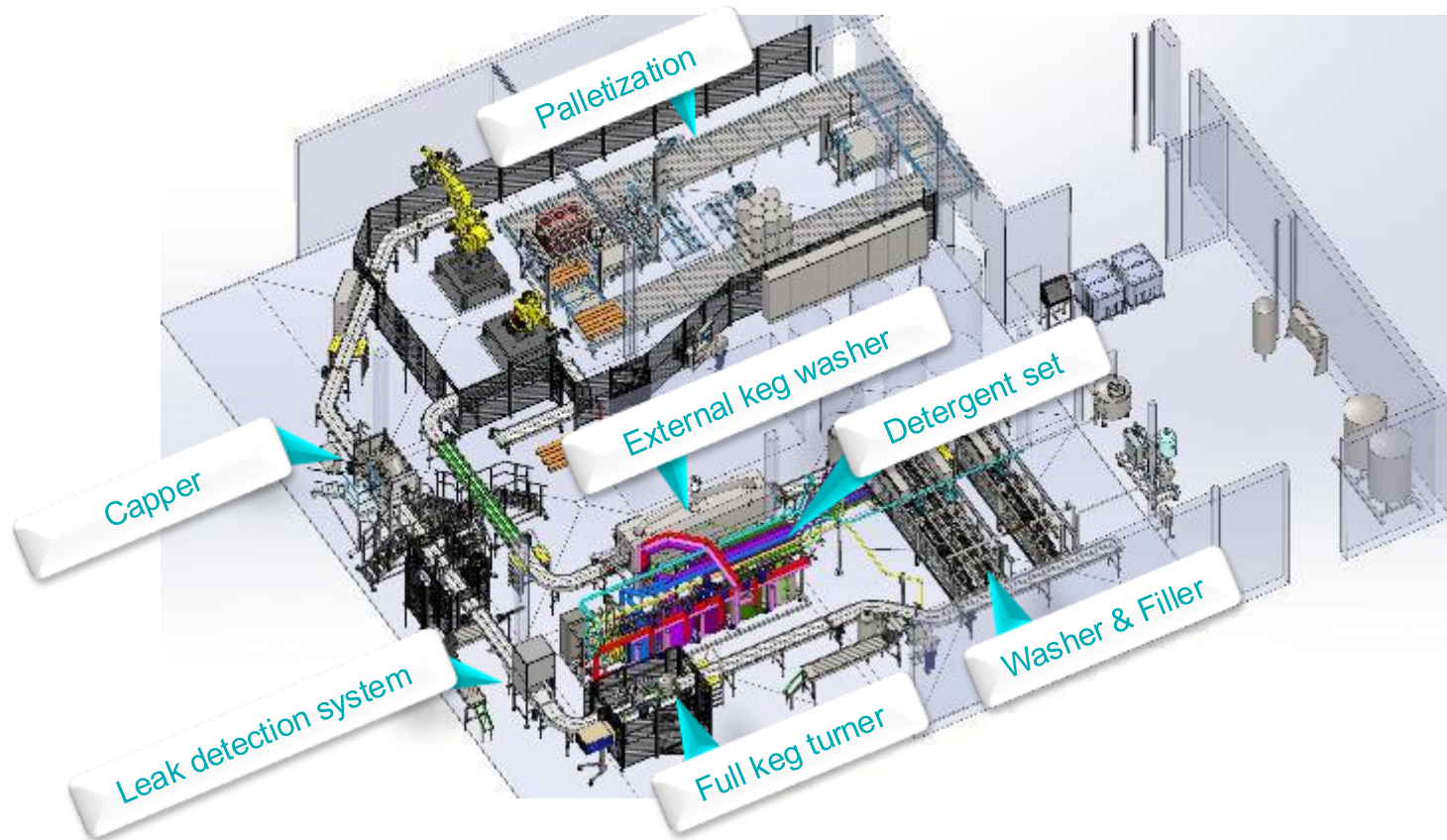



NEW CROWN

Company presentation



Specialist in upgrading RGB beverage lines to maximize efficiency, performance and quality.

New Crown helps beverage producers get the most from their existing lines by optimizing processes, standardizing best practices, and integrating new technologies. New Crown works closely with local teams, provide frequent on-site support, and offer strong remote assistance.

Key solutions, services & products

- Optimizing existing processes
- Standardizing best practice solutions
- Integrating new technologies
- Reducing energy consumptions
- Supporting our customers

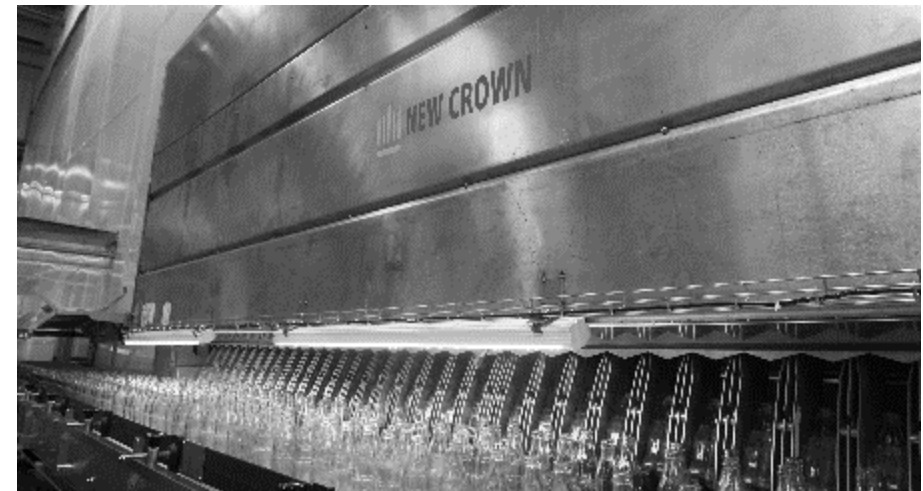

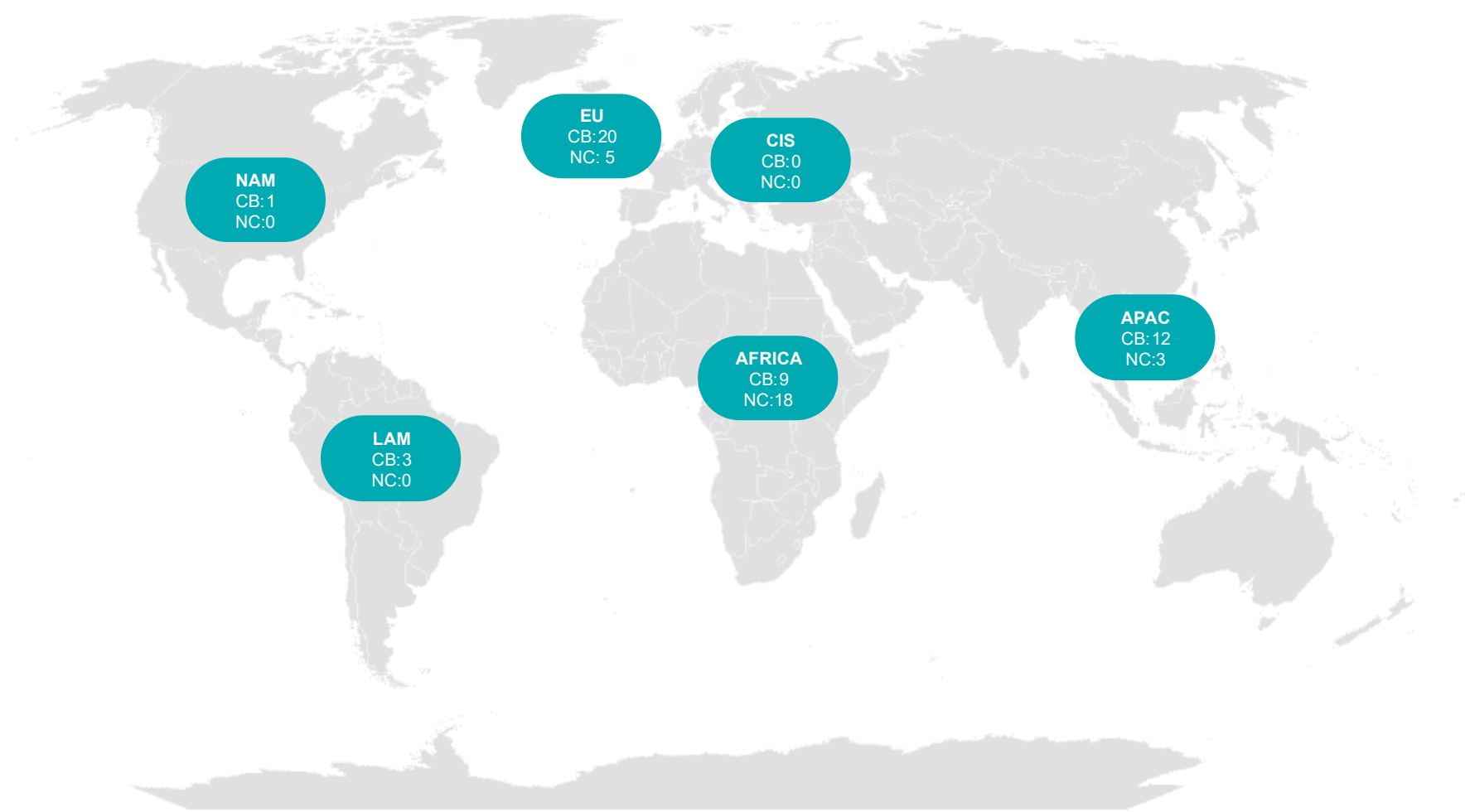



NEW CROWN



SERVICES

Engineering services

- Upgrades and Retrofits of (glass) bottling equipment
- Bottle washer – bottle filler & pasteurizer solutions
- End of line solutions
- Automation and electrical upgrades
- Line optimization
- Line re-location

Onsite services

- Installation & Commissioning
- Project management
- Audits and inspections
- Maintenance services and customer follow-up
- Troubleshoot and repairs
- Software and automation services

PRODUCTS

- Optimizing by restoring to basic conditions
- Optimizing by replacing subassemblies
- Optimizing by automating processes
- Spare parts

Product portfolio



ONSITE SERVICES



- Audits
- Overhauls
- Upgrades & Retrofits
- Installations
- Relocations

Service Level Agreements

- Always tailor-made to customer needs
- Elaboration of maintenance plan
- Short- and long-term maintenance scheduling
- Short- and long-term cost projections
- Inclusion of upgrades and improvements
- Dedicated account engineer
- Continuous follow-up and remote support
- Frequent site visits
- Operator/maintenance Trainings

Product portfolio



OPTIMIZING



OPTIMIZING by restoring to basic conditions

- Maintenance and overhauls with spare parts
- Making theoretical capacity meet real output



OPTIMIZING by automation of processes

- Software PLC & HMI updates
- Process modifications
- Digitalization of parameters
- Data centralization

Product portfolio



OPTIMIZING



OPTIMIZING by replacing subassemblies

- Many standardized subassemblies
- Technology with proven effectivity
- For any brand and any type

Product portfolio



SPARE PARTS



Spare parts

- OEM parts for Crown-Baele machines
- Selected parts for other brands (Sidel, Simonazzi, KHS, O&H)
- Reverse engineered & improved parts of other brands and makes

References & Clients



AB-Inbev • Leuven • Alrode Brewery • Ibhayi Brewery • Rosslyn Brewery • Kgalagadi brewery • Cervejas de Moçambique • **ECCBC** • Ceris – Cavibel • Atlas company Marrakesh • Bonagui S.A. • Coca-Cola Bottling Co. of Ghana • Atlas Bottling Company Oujda • Atlas Bottling Company Tanger • Fruital-Alger • **Coca-Cola Europacific Partners** • Coca Cola Chaudfontaine • Coca Cola Wilrijk • Coca-Cola HBC Croatia • Coca-Cola HBC Polska • **Castel** • Sacofrina S.A Bracongo • Brasimba Lubumbashi • Castel Malawi • Sobraga Port-Gentil, Libreville • Sobragui Conakry • Leake Tesfay Bota • **Cosmos Brewery** • Fuengfuanant Co • Kankwan Co. • S.S. Karnsura • **Heineken** • Lao Brewery Co. Ltd • Heineken Saint Lucia • Heineken Nederland • Bralima Kinshasa • Bralima Kisangani • Bralima Lubumbashi • Bralirwa Gisenyi • Surinaamse Brouwerij • Het Anker NV • Meens Bierbrouwerij • **Carlsberg** Brewery Malaysia Berhad • Brouwerij Bosteels NV • Brouwerij Lindemans NV • Brouwerij Der Trappisten CVBA • Bierbrouwerij De Koningshoeven BV • Ordal BVBA • Olympia NV • Grolsche • Palm • Bierbrouwerij • San Pellegrino S.P.A. • **Danone**, Source Badoit • SA **Roxane** Alençon • Roxane Nord Genay CFBG • Maine Soft Drinks • San Pellegrino S.P.A. • **Super bock**, Águas Pedras salgadas • Castel de Vide • Les Brasseries Sleeman